



# Smart Valve Positioner 700 Series

FUNCTIONAL SPECIFICATIONS		
Specification item	Description	
Model	AVP701 : 4 to 20 mA, HART Protocol, w/travel transmission	
	AVP702 : 4 to 20 mA, HART Protocol	
	AVP703 : FOUNDATION™ fieldbus	
Actuator type	Pneumatic actuator, single or double acting	
Input signal (AVP701/ 702)	4 to 20 mAdc (Signal range configurable for sprit ranging (min. span 4mA) ) Minimum driving current : 3.84 mA	
Input resistance (AVP701/ 702)	475 Ω typically / 20 mAdc (w/o the overvoltage protection) 600 Ω typically / 20 mAdc (w/ the overvoltage protection)	
HART Protocol Version (AVP701/ 702)	Version 7	
Supply voltage (AVP703)	9-32 V	
Maximum currnet (AVP703)	20 mA	
Fieldbus Foundation Interoperability Test (AVP703)	ITK6.1	
Lightning protection	Peak value of voltage surge: 12 kV, Peak value of current surge: 1000 A	
Output characteristics	Linear, Equal Percentage, Quick opening Custom configurable 21 segments	
Bypass operation	Possible by external Auto/Manual switch or LUI operation	
Supply pressure	140 kPa to 700 kPa	
Air consumption	Single acting 3.2 l/min(N) or less at supply pressure of 140 kPa and 50% output steady state 4 l/min(N) or less at supply pressure of 280 kPa and 50% output steady state 4.8 l/min(N) or less at supply pressure of 500 kPa and 50% output steady state Double acting 8 l/min(N) or less at supply pressure of 400 kPa and 70% balance pressure steady state	
Maximum air deliver flow rate	110 l/min(N) or more at supply pressure of 140 kPa	
Air connection	Rc 1/4 or 1/4NPT	
Electrical connection	G1/2, 1/2NPT, and M20	
Ambient temperature limit	-40 to +80°C (temperature range varies depending on the Flameproof Type.), operating temperature range of LCD : 0 to 50 °C	
Ambient humidity limit	5 to 100% RH	
Vibration tolerance	20 m/s <sup>2</sup> (5 to 400 Hz) with standard mounting kit on Azbil HA actuator	
Finish	Baked acrylic, Silver color	
Material (casing)	Aluminum die cast	
Weight	4.2 kg	
Performance	Accuracy	±1.0%F.S. (±2.5%F.S. with custom output characteristics modification)
	Travel transmission accuracy (AVP701)	±1.0%F.S. (±2.5%F.S. with custom output characteristics modification)
	Stem travel range	14.3 to 100 mm (feedback lever angle ±4° to ±20°)
Structure and Approvals	General (water proof) TIIS Flameproof FM Explosionproof/ Dust Ignition Protection FM Intrinsically safe (ic) and Nonincendive FMC Explosionproof/ Dust Ignition Protection ATEX Flameproof/ Dust Ignition Protection IECEX Flameproof/ Dust Ignition Protection NEPSI Flameproof/ Dust Ignition Protection KOSHA Flameproof EAC Flameproof INMETRO Flameproof/ Dust Ignition Protection	
Electromagnetic compatibility	EN 61326-1: 2013 (CE Marking)	

Please read "Terms and Conditions" from the following URL before ordering and use.

<http://www.azbil.com/products/factory/order.html>

FOUNDATION is a registered trademark of Fieldbus Foundation.  
HART is a registered trademark of HART Communication Foundation.  
Other product names, model numbers and company names may be trademarks of the respective company.

[Notice] Specifications are subject to change without notice.  
No part of this publication may be reproduced or duplicated without the prior written permission of Azbil Corporation.

**Azbil Corporation**  
Advanced Automation Company

*Yamatake Corporation changed its name to Azbil Corporation on April 1, 2012.*

1-12-2 Kawana, Fujisawa  
Kanagawa 251-8522 Japan  
URL: <http://www.azbil.com>

1st Edition : issued in May, 2014-AZ  
2nd Edition : issued in Jun, 2017-AZ



- 1 Excellent environmental resistance and robustness
- 2 Advanced control valve diagnostic and system integration
- 3 Improved energy efficiency and controllability

# Smart Valve Positioner 700 Series

The Smart Valve Positioner 700 Series (model number: AVP7\*\*) not only inherits the reliability of the core technology established by the 300 Series but has advanced control valve diagnostic techniques and the latest system integration technology.

The Smart Valve Positioner 700 Series provides numerous benefits for various stages in the life cycle of users' plants and contributes to the improvement of plant productivity.



## FIVE FEATURES

### POINT 1 Excellent environmental resistance and robustness

Azbil's unique isolating structure separates the electrical/electronic parts, air circuits, and terminal box from each other, achieving high environment resistance. In addition, the improved travel sensor provides better vibration resistance. These features provide what is most important for field equipment: long-term high reliability.

### POINT 2 Comprehensive control valve diagnosis

With newly added pressure sensors in the positioner, it is possible to measure the supply air pressure, nozzle back pressure, and output air pressure. The control valve diagnostic algorithms, which determines the soundness of the control valve based on the measured values of those pressures, have been enhanced.

The measured pressures are used for both offline commands in which the soundness of the control valve is determined based on its response to commands sent from the host device when the plant is shut down, and online diagnosis, in which the soundness of the control valve is determined based on the information collected during the operation of the plant. This supports the implementation of status-based maintenance and predictive maintenance.

### POINT 3 Do-from-anywhere adjustment and setup

The new adjustment/setting mechanism (local user interface: LUI) is a combination of an LCD and push buttons mounted on the front of the positioner that allows users to operate the positioner without compromising the explosion-proof construction.

It is also possible to make adjustments and settings from various portable adjustment/setting tools and networked device management systems.

Because users can access the positioner from anywhere, including the worksite, maintenance shop, and control room, adjustment and settings configuration work before operation, and also troubleshooting, can be done more efficiently.

### POINT 4 Advanced system integration

The Smart Valve Positioner 700 Series supports the HART protocol, which is the de facto communication standard in the plant industry, and the latest version of FOUNDATION™ fieldbus, and has been certified by both organizations. Support for latest communication standards allows the host device to make the best use of information on control valve operating status and diagnostic results.

### POINT 5 Improved energy efficiency and controllability

The basic performance of the Smart Valve Positioner 700 Series as a positioner has also been improved. Compared to our previous products, we have reduced the consumption of instrumentation equipment air during steady operation by 20%, helping to save energy in plant operation.

Also, the newly developed double-acting pilot relay improves the operating speed of large control valves by 20% compared to our previous products.

POINT 1

# Excellent environmental resistance and robustness

Control valves and positioners are required to operate continuously over a long period of time even in severe environments such as corrosive gas atmospheres in a plant or coastal regions at risk of salt corrosion. In addition, because they are built into the piping system, they are also at risk of exposure to strong vibration. Based on the solid performance demonstrated by the 300 Series, the 700 Series is designed to have high reliability even in such severe environments for a long period of time.

## Isolating structure for electrical/electronic parts

The electrical/electronic parts, which consist of printed-circuit boards, an LCD, a travel sensor, and coils, are stored in an explosion-proof enclosure.

The air circuits, through which instrumentation equipment air potentially containing oil or water mist passes, and the terminal box, which may come into contact with atmosphere containing moisture or corrosive gas, reside outside of the explosion-proof enclosure. This structure prevents the electrical/electronic parts from being exposed to these risk factors and enhances the reliability of the equipment.

In addition, placing the air circuits outside of the explosion-proof enclosure allows users to carry out maintenance on the air circuits (such as cleaning the nozzle flapper) even in explosive atmospheres.

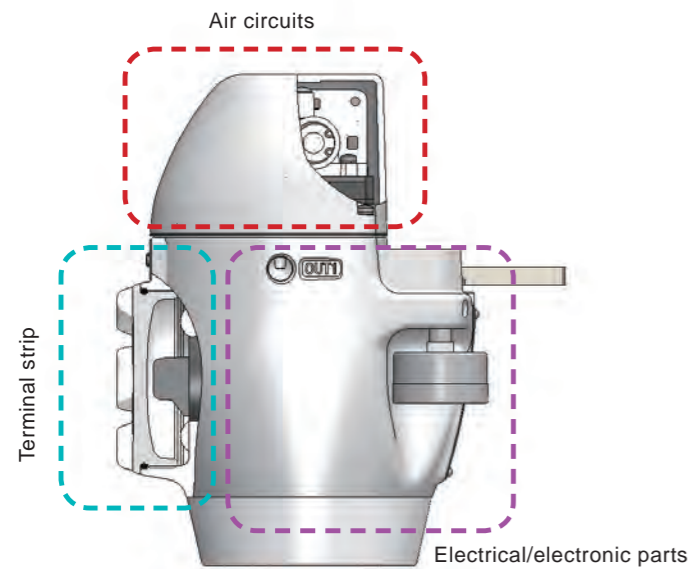

## Travel sensor with improved vibration resistance

A non-contact magnetostrictive (MR) sensor, which sold over 700,000 units, has been adopted as the travel sensor.

The 700 Series provides even better vibration resistance by improving the bearing that supports the rotary movement of the shaft that conveys variations to the MR sensor.

This boosts the reliability of the 700 Series even higher.

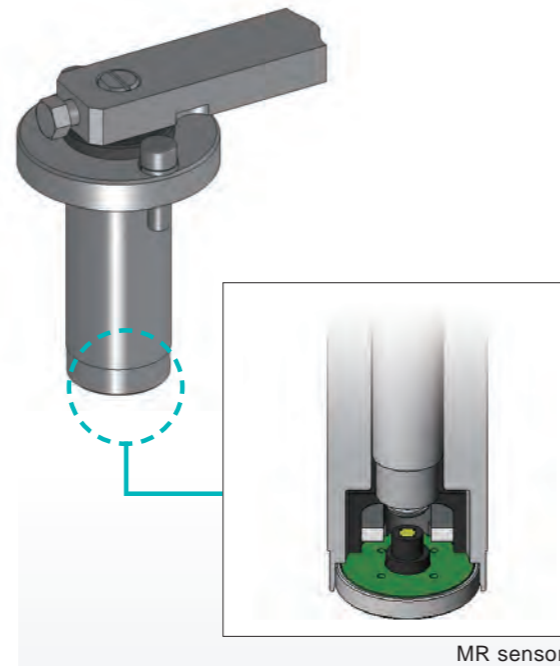

POINT 2

# Comprehensive control valve diagnosis

The 700 Series is equipped with new pressure sensors for measuring the supply air pressure, nozzle back pressure, and output air pressure.

It is now possible to know if there is an abnormality in a control valve, and the progress of deterioration, based on measured values or the calculated values determined by the control valve specifications.

The tried-and-trusted online diagnostic algorithms developed exclusively by Azbil have also been refined to a higher level of performance in order to provide valuable information in support of status-based maintenance and predictive maintenance.

## Valve signature

Valve signature is the result of plotting the amount of control valve travel in response to positioner output air pressure following a ramp input signal. Through the execution of this test, the following indicators of the control valve's performance are obtained, and its soundness can be determined from that information.

- Seating force (valve closing force)
- Frictional force
- Spring range
- Stick-slip

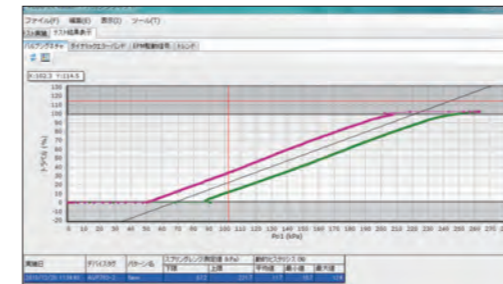

## Air circuit diagnosis

If oil, moisture, or other foreign substances enter the instrumentation equipment air due to an equipment failure, they often accumulate in the positioner and can cause it to malfunction. The air circuit diagnostics provide a diagnostic algorithm for detecting the progression of the accumulation of foreign substances through a tendency comparison of the relationship between the control signal and nozzle back pressure in the positioner. The positioner identifies trends caused by accumulation of foreign substances in the nozzle flapper and clogging of the seat area and informs the user when to perform maintenance on the air circuits.

## Force-balance diagnosis

Control valves function with a balance between the unbalance force generated by the fluid pressure, valve seating force, frictional force generated by gland packings, spring force of the actuator, and operation thrust force generated by the output air pressure from the positioner and the actuator diaphragm.

Force-balance diagnosis provides an online algorithm for diagnosing whether these forces are properly balanced for control valve actuation.

There are two types of force-balance diagnosis: output air pressure validity diagnosis (P<sub>O</sub> Validity) and maximum frictional force diagnosis (Max. Friction).

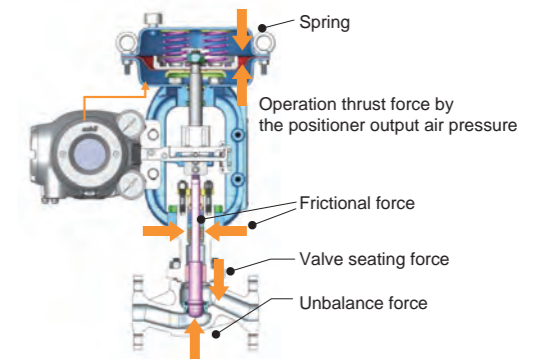

## Improved stick-slip diagnosis

The phenomenon of alternating stick and slip of the valve stem due to an increase in sliding resistance arising in a control valve is called stick-slip. Stick-slip diagnosis is Azbil's own unique control-valve diagnostic algorithm for detecting this phenomenon online.

In addition to the stick-slip diagnostic algorithm which was implemented in the 300 Series, the 700 Series provides exception handling of non-stationary operation data and a gradual threshold setting function, both of which increase the usefulness of this diagnostic algorithm.

Of course, all diagnostic algorithms and checking functions implemented in the 300 Series have been inherited by the 700 Series.

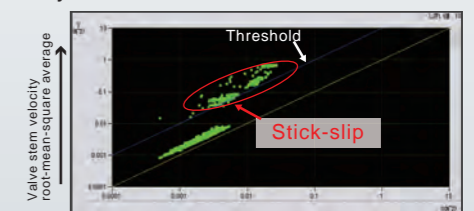

## POINT 3

## Do-from-anywhere adjustment and setup

Adjustments, setting changes, and access to the self-diagnostic information of the 700 Series are possible from any location, at any time, and in any environment. The latest communication technology and man-machine interface technology provide necessary access when and where the user wants.

### Local user interface (LUI)

The positioner has four magnetic-reed-switch push buttons and liquid crystal display instrumentation which can be operated even in explosive atmospheres from the front of the positioner. The LUI enables the following operations:

- Execution of Auto-setup (automatic adjustment programs)
- Display of self-diagnostic information
- Display of various variables (input signal, opening, output air pressure, supply air pressure, etc.)
- Display and change of positioner settings (actuator size, actuator action, packing parameters, etc.)
- Software-like switching to manual operation using a regulator



Operation using the LUI

### Adjustment/setup tools

Users can make adjustments or change the settings of the 700 Series with various portable tools that are compliant with DD/EDD or FDT technologies.

These tools are especially useful for maintenance shop work.



Operation using a portable PC

### Device management system

If the control system supports the HART protocol or FOUNDATION™ fieldbus, and the device management system supports the EDDL and/or FDT standards, information from the 700 Series can be accessed from the control room.



Operation using the device management system

## POINT 4

## Advanced system integration

The application of advanced system integration technologies is essential to providing a means to achieve early detection of control valve abnormalities, enhanced monitoring of important control valves, and efficient control valve checking operations.

The 700 Series accomplishes all of these goals by conforming to the latest communication standards and systematizing the related software.

### Support for the HART protocol and FOUNDATION™ fieldbus

The 700 Series is certified for Version 7 of the HART standard and ITK 6.1 of the FOUNDATION™ fieldbus standard. This ensures interoperability with various host devices.

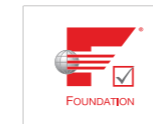

### Support for FDT technology

To enable access to the 700 Series from a host device (FDT frame application) that complies with the FDT (Field Device Tool) standard, Azbil will offer dedicated DTM (Device Type Manager) software.

This will make the superior functions of the 700 Series available to the many device management systems that employ FDT technology.



### PLUG-IN Valstaff

The PLUG-IN Valstaff application, which maximizes the real strength of the 700 Series, can be incorporated into InnovativeField Organizer (IFO), Azbil's device management system, and Plant Resource Manager (PRM), Yokogawa Electric Corporation's device management system.



## POINT 5

## Improved energy efficiency and controllability

The basic performance of the 700 Series as a positioner has also been improved. Compared to our previous products, we have reduced the consumption of instrumentation equipment air during steady operation by 20%, contributing to energy efficiency in plant operation.

The newly developed double-acting pilot relay improves the operating speed of large control valves by 20% compared to our previous products.

